



ANDEX(HONG KONG) LIMITED

Hong Kong Head Office:

Tel: (852) 2790 3299 Fax: (852) 2763 5628
Http://www.andexlimited.com
E-mail: adx@andexlimited.com

Shanghai Office:

Tel: (021) 5308 2857, 5308 5821 Fax: (021) 5308 1339
E-mail: songlong-sh@china.com

Shenzhen Office:

Tel: (0755) 8242 8684, 8242 8685 Fax:(0755) 8242 8677
E-mail: andex@21cn.net

Varistor



HEL

HEL
10D471K



HOW TO ORDER

訂貨說明

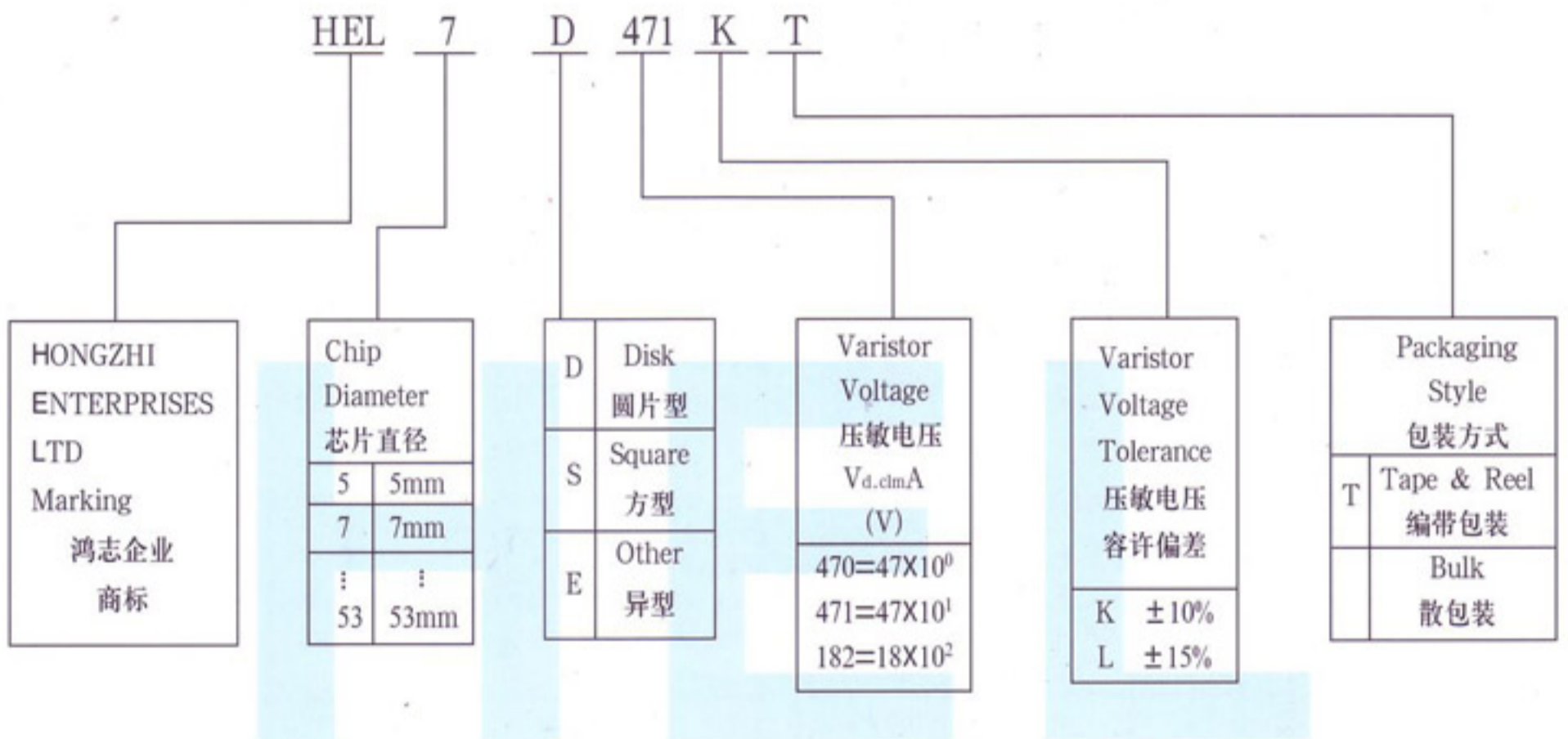
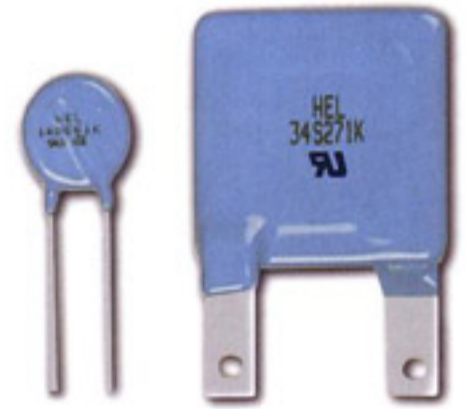

CQC	File No. CQC04001010848	China 中國CCC認證	
	File No. 215101	Canada 加拿大CSA認證	
	File No. 40008621	Germany 德國VDE認證	
	File No. E197799	U.A.S 美國UL認證	



Standard Varistor List 通用壓敏電阻一覽表

Table 1

型號 規格 Model Number	壓敏 電壓 Varistor Voltage	最大允許 使用電壓 Max. Allowable Voltage		能量耐量 Max. Energy (10/1000μS) (Joule)	通流量 Max. Peak Current (8/20μS) I time (kA)
		AC (V)	DC (V)		
HEL-5D180L HEL-7D180L HEL-10D180L HEL-14D180L HEL-20D180L	15.5-21	11	14	0.6 1.1 2.3 5.2 13	0.25 0.5 1 2 3
HEL-5D220K HEL-7D220K HEL-10D220K HEL-14D220K HEL-20D220K	20-24	14	18	0.7 1.3 2.6 6.3 16	0.25 0.5 1 2 3
HEL-5D270K HEL-7D270K HEL-10D270K HEL-14D270K HEL-20D270K	24-30	17	22	0.9 1.6 3.9 7.8 19	0.25 0.5 1 2 3
HEL-5D330K HEL-7D330K HEL-10D330K HEL-14D330K HEL-20D330K	30-36	20	26	1.1 2.0 4.8 9.5 24	0.25 0.5 1 2 3
HEL-5D390K HEL-7D390K HEL-10D390K HEL-14D390K HEL-20D390K	35-43	25	31	1.2 2.4 5.6 11 28	0.25 0.5 1 2 3
HEL-5D470K HEL-7D470K HEL-10D470K HEL-14D470K HEL-20D470K	42-52	30	38	1.5 2.8 6.8 14 34	0.25 0.5 1 2 3
HEL-5D560K HEL-7D560K HEL-10D560K HEL-14D560K HEL-20D560K	50-62	35	45	1.8 3.4 8.1 16 41	0.25 0.5 1 2 3
HEL-5D680K HEL-7D680K HEL-10D680K HEL-14D680K HEL-20D680K	61-75	40	56	2.2 4.5 10 20 49	0.25 0.5 1 2 3
HEL-5D820K HEL-7D820K HEL-10D820K HEL-14D820K HEL-20D820K	74-90	50	65	3.5 7.0 14 28 56	0.8 1.75 3.5 6 10
HEL-5D101K HEL-7D101K HEL-10D101K HEL-14D101K HEL-20D101K	90-110	60	85	4.0 8.5 17 35 72	0.8 1.75 3.5 6 10

Table 2

型號 規格 Model Number	壓敏 電壓 Varistor Voltage	最大允許 使用電壓 Max. Allowable Voltage		能量耐量 Max. Energy (10/1000μS) (Joule)	通流量 Max. Peak Current (8/20μS) I time (kA)
		AC (V)	DC (V)		
HEL-5D121K HEL-7D121K HEL-10D121K HEL-14D121K HEL-20D121K	108-132	75	100	4.5 10 20 42 88	0.8 1.75 3.5 6 10
HEL-5D151K HEL-7D151K HEL-10D151K HEL-14D151K HEL-20D151K	135-165	95	125	6.5 13 25 53 106	0.8 1.75 3.5 6 10
HEL-5D181K HEL-7D181K HEL-10D181K HEL-14D181K HEL-20D181K	162-198	115	150	7.5 15 32 65 130	0.8 1.75 3.5 6 10
HEL-5D201K HEL-7D201K HEL-10D201K HEL-14D201K HEL-20D201K	185-225	130	170	9.0 18 35 70 160	0.8 1.75 3.5 6 10
HEL-5D221K HEL-7D221K HEL-10D221K HEL-14D221K HEL-20D221K	198-242	140	180	9.0 19 39 78 180	0.8 1.75 3.5 6 10
HEL-5D241K HEL-7D241K HEL-10D241K HEL-14D241K HEL-20D241K	216-264	150	200	10.5 21 42 84 200	0.8 1.75 3.5 6 10
HEL-5D271K HEL-7D271K HEL-10D271K HEL-14D271K HEL-20D271K	243-297	175	225	12 24 49 99 210	0.8 1.75 3.5 6 10
HEL-5D301K HEL-7D301K HEL-10D301K HEL-14D301K HEL-20D301K	270-330	195	250	13 26 54 108 216	0.8 1.75 3.5 6 10
HEL-5D331K HEL-7D331K HEL-10D331K HEL-14D331K HEL-20D331K	297-363	210	275	15 29 58 115 228	0.8 1.75 3.5 6 10
HEL-5D361K HEL-7D361K HEL-10D361K HEL-14D361K HEL-20D361K	324-396	230	300	16 32 65 130 255	0.8 1.75 3.5 6 10



Standard Varistor List 通用壓敏電阻一覽表

Table 3

型號 規格 Model Number	壓敏 電壓 Varistor Voltage	最大允許 使用電壓 Max. Allowable Voltage		能量耐量 Max. Energy (10/1000μS) (Joule)	通流量 Max. Peak Current (8/20μS) (kA)
		AC (V)	DC (V)		
HEL-5D391K HEL-7D391K HEL-10D391K HEL-14D391K HEL-20D391K	351-429	250	320	17 35 70 140 275	0.8 1.75 3.5 6 10
HEL-5D431K HEL-7D431K HEL-10D431K HEL-14D431K HEL-20D431K	387-473	275	350	20 40 80 155 303	0.8 1.75 3.5 6 10
HEL-5D471K HEL-7D471K HEL-10D471K HEL-14D471K HEL-20D471K	423-517	300	385	21 42 85 175 350	0.8 1.75 3.5 6 10
HEL-5D511K HEL-7D511K HEL-10D511K HEL-14D511K HEL-20D511K	459-561	320	418	22 45 92 190 382	0.8 1.75 3.5 6 10
HEL-5D561K HEL-7D561K HEL-10D561K HEL-14D561K HEL-20D561K	504-616	350	460	23 46 92 192 385	0.8 1.78 3.5 6 10
HEL-5D621K HEL-7D621K HEL-10D621K HEL-14D621K HEL-20D621K	558-682	385	505	24 48 97 195 390	0.8 1.75 3.5 6 10

Table 4

型號 規格 Model Number	壓敏 電壓 Varistor Voltage	最大允許 使用電壓 Max. Allowable Voltage		能量耐量 Max. Energy (10/1000μS) (Joule)	通流量 Max. Peak Current (8/20μS) (kA)
		AC (V)	DC (V)		
HEL-5D681K HEL-7D681K HEL-10D681K HEL-14D681K HEL-20D681K	612-748	420	560	25 53 100 200 400	0.8 1.75 3.5 6 10
HEL-7D751K HEL-10D751K HEL-14D751K HEL-20D751K	675-825	460	615	55 105 210 420	1.75 3.5 6 10
HEL-7D781K HEL-10D781K HEL-14D781K HEL-20D781K	702-858	485	640	53 105 225 445	1.75 3.5 6 10
HEL-7D821K HEL-10D821K HEL-14D821K HEL-20D821K	738-902	510	670	57 110 235 460	1.75 3.5 6 10
HEL-10D911K HEL-14D911K HEL-20D911K	819-1001	550	745	130 255 510	3.5 6 10
HEL-10D951K HEL-14D951K HEL-20D951K	855-1045	575	765	135 270 535	3.5 6 10
HEL-10D102K HEL-14D102K HEL-20D102K	900-1100	625	825	140 280 565	3.5 6 10
HEL-10D112K HEL-14D112K HEL-20D112K	990-1210	680	895	155 310 620	3.5 6 10
HEL-10D182K HEL-14D182K HEL-20D182K	1620-1980	1000	1465	247 510 1020	3.5 6 10

系列 S size	壓敏電壓 Voltage	D max.	H max.	W ±1	φ ±0.03	T max.
5D	18~270V	6	9	5	0.6	4
	300~680V	7	10	5	0.6	5
7D	18~270V	8	11	5	0.6	5
	300~820V	9	12	5	0.6	7
10D	18~270V	11	14	7.5	0.8	6
	300~820V	12	15	7.5	0.8	8
14D	18~270V	15	18	7.5	0.8	6
	300~1100V	16	19	7.5	0.8	8
	1800V	17	20	15	0.8	10
20D	18~270V	21	24	10	1.0	7
	300~1100V	22	25	10	1.0	9
	1800V	23	26	15	1.0	11

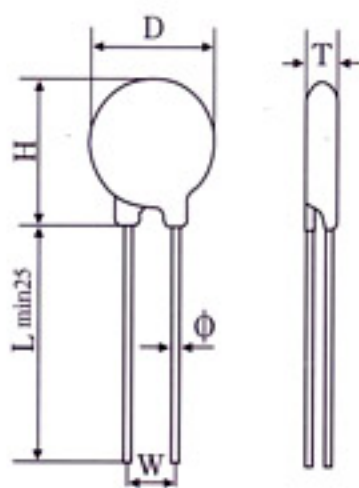



HIGH ENERGY SERIES 高能量壓敏電阻一覽表

Table 1

型號 規格 Model Number	最大允許 使用電壓 Max. Allowable voltage	能量耐受 Max. Energy (10/1000μS)	通流量 Max. Peak Current (8/20μS)
	AC (V)	(Joule)	(kA)
25D201K	130	170	15
32D201K		210	25
40D201K		310	40
34S201K		310	40
53D201K		490	70
25D221K	140	180	15
32D221K		225	25
40D221K		330	40
34S221K		330	40
53D221K		530	70
25D241K	150	190	15
32D241K		240	25
40D241K		360	40
34S241K		360	40
53D241K		570	70
25D271K	175	200	15
32D271K		250	25
40D271K		390	40
34S271K		390	40
53D271K		630	70
25D301K	190	230	15
32D301K		260	25
40D301K		410	40
34S301K		410	40
53D301K		680	70
25D331K	210	250	15
32D331K		280	25
40D331K		430	40
34S331K		430	40
53D331K		700	70
25D361K	230	280	15
32D361K		300	25
40D361K		460	40
34S361K		460	40
53D361K		730	70

Table 2

型号 规格 Model Number	最大允許 使用電壓 Max. Allowable voltage	能量耐受 Max. Energy (10/1000μS)	通流量 Max. Peak Current (8/20μS)
	AC (V)	(Joule)	(kA)
25D391K	250	315	15
32D391K		330	25
40D391K		490	40
34S391K		490	40
53D391K		880	70
25D431K	275	340	15
32D431K		360	25
40D431K		550	40
34S431K		550	40
53D431K		950	70
25D471K	300	360	15
32D471K		380	25
40D471K		600	40
34S471K		600	40
53D471K		1000	70
25D511K	320	400	15
32D511K		430	25
40D511K		640	40
34S511K		640	40
53D511K		1100	70
25D561K	350	440	15
32D561K		480	25
40D561K		720	40
34S561K		720	40
53D561K		1150	70
25D621K	385	460	15
32D621K		550	25
40D621K		800	40
34S621K		800	40
53D621K		1200	70
25D681K	420	480	15
32D681K		600	25
40D681K		910	40
34S681K		910	40
53D681K		1500	70

Table 3

型號 規格 Model Number	最大允許 使用電壓 Max. Allowable voltage	能量耐受 Max. Energy (10/1000μS)	通流量 Max. Peak Current (8/20μS)
	AC (V)	(Joule)	(kA)
25D781K	485	510	15
32D781K		600	25
40D781K		920	40
34S781K		920	40
53D781K		1600	70
25D821K	510	525	15
32D821K		620	25
40D821K		940	40
34S821K		940	40
53D821K		1800	70
25D911K	550	540	15
32D911K		620	25
40D911K		960	40
34S911K		960	40
53D911K		2200	70
25D102K	625	600	15
32D102K		700	25
40D102K		1055	40
34S102K		1055	40
53D102K		2500	70
25D122K	750	700	15
32D122K		900	25
40D122K		1260	40
34S122K		1260	40
53D122K		3000	70
25D162K	900	1025	15
32D162K		1220	25
40D162K		1680	40
34S162K		1680	40
53D162K		4000	70
25D182K	1000	1150	15
32D182K		1350	25
40D182K		1890	40
34S182K		1890	40
53D182K		4500	70

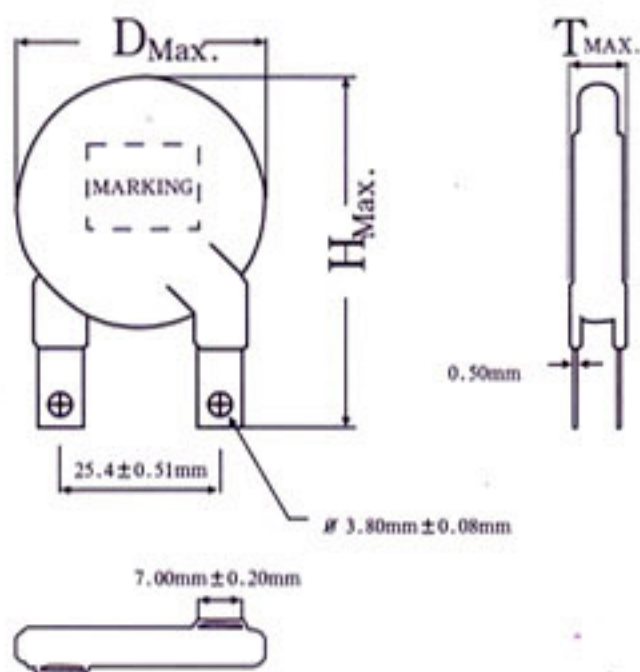

Size	D(mm)	H(mm)
25D	29	50
32D	36	56
40D	45	62
53D	58	78
34S	37	58

Voltage	T(mm)
201 ~ 271	11
301 ~ 621	12
681 ~ 911	14
102 ~ 122	16
142 ~ 182	18